



Multi task touch module One OTRD

AQ7280 Series
Optical Time Domain Reflectometer

Precision Making

Bulletin AQ7280-01EN



In 2002, Yokogawa Test&Measurement became a leading supplier of optical test and measurement solutions following the acquisition of Ando Electric.

An industry pioneer with over 40 years of experience in optoelectronic technology and real world lab and field testing, Yokogawa delivers field test equipment solutions with world renowned quality and exceptional performance.

Designed in response to the growing need for reliable and easy-to-use field test instruments for installation and maintenance of fiber optic networks, the Yokogawa Test&Measurement AQ7280 Optical Time Domain Reflectometer (OTDR) empowers field technicians to confidently make fast and precise measurements.

The AQ7280 OTDR satisfies a broad range of test and measurement needs in research, manufacturing and optical network analysis, from access to core and delivers:

RELIABILITY – The AQ7280's robust design allows for operation in harsh field conditions and its proven operating system assures stability, prompt response, and superior protection against software virus attacks.

EASE-OF-USE – This instrument boasts dual-operation modes through a multi-touch touchscreen and hard-key buttons and enables fully-automatic measurements and easy-to-read analytic reports through new software applications.

SPEED – With lightning-fast startup and immediate reporting via wireless connectivity, this OTDR's multi-tasking operation enhances productivity.



Modular OTDR

The AQ7280 OTDR offers first-class performance thanks to updated functions, a large capacity battery, and a large user-friendly screen. Additional benefits that ensure measurement quality and improve work efficiency include:

Full range of selections

- Up to 14 OTDR units to choose from
- Customizable with five optional modules
- 84 potential combinations^{*1}

Proven reliability

- High SNR mode ensures high trace quality.
- Maximum 15 hours battery operation

Quick and easy to use

- 8.4-inch high luminance color LCD
- Smartphone-like usability

Operability

- Multi-fiber measurement up to 2000 fibers
- Auto-execute multiple measurements and analyses with Smart Mapper

Much more than an OTDR

- A variety of optional features for multi-tasking
- Application software that facilitates analysis

^{*1} This includes combinations with the cover bracket instead of OPM (Optical Power Meter)/VLS (Visible Light Source) modules.

Touch panel application menu

The 8.4-inch touchscreen enables intuitive operation. Select the desired function by simply tapping the icon on the main menu.

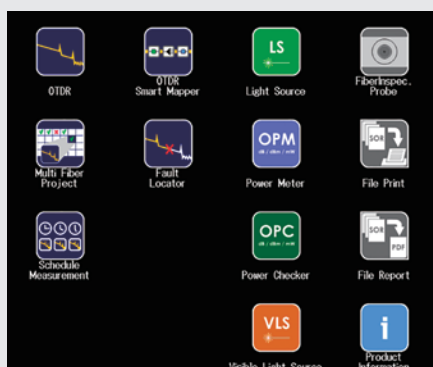

Function icons on the main menu

No special tools needed

The hardware for the OTDR units, option modules, and battery cover can be removed and put back using common work tools, even coins, to allow for quick and easy replacements and tweaks even when in the field.



Installation screws can be easily turned with readily-available tools, even coins



Optical Time Domain Reflectometer AQ7280 Series

For information on products and firmware updates, please visit:

<https://tmi.yokogawa.com/p/aq7280>



Yokogawa
Test&Measurement
Over four decades
of OTDR expertise



Full range of selections

The AQ7280 OTDR series is a modular OTDR with an extensive lineup of 13 detachable units and five OPM/VLS modules.

The AQ7280 works for customers with a wide variety of applications including structured cable testing, cable manufacturing, and network installation and maintenance from core network to FTTH.



YOKOGAWA OTDR model map

For fiber optic installation

Cable type	Target network		Test application						
	Area ^{*1}		PON	Installation (measurement of new and dark lines)		Installation/Maintenance (measurement of new and live lines)			
				Model	Wavelength (nm) Dynamic range (dB)	Model	Wavelength (nm) Dynamic range (dB)		
Single-mode optical fiber cable	Access	38 dB	1×32	AQ7282	A	1310 1550 38 36			
					G	1310 1550 1490 38 36 36			
	Access/Metro	42 dB	1×64	AQ7283	A	1310 1550 42 40	AQ7283	E	1310 1550 1625 42 40 40 ^{*2}
					H	1310 1550 1625 42 40 39		F	1310 1550 1650 42 40 40 ^{*2}
					K	1310 1550 1625 1490 42 40 40 38			
	Metro/Core	46 dB	—	AQ7284	A	1310 1550 46 45			
H					1310 1550 1625 46 45 44				
Core	50 dB	—	AQ7285	A	1310 1550 50 50				

For optical fiber research and manufacturing

Cable type	Target application	Model	Wavelength (nm) Dynamic range (dB)	
Single-mode optical fiber cable	Research/Manufacturing	AQ7286	A	1310 1550 42 40
			H	1310 1550 1625 42 40 39
			J	1310 1550 1625 1383 42 40 39 39

*1 The dB value is the maximum dynamic range of OTDRs for each target area

*2 A built-in cut filter to isolate from communication wavelengths included

AQ7282A, AQ7283A, AQ7284A, AQ7285A

These are two-wavelength modules with 1310/1550 nm wavelengths, commonly used in fiber optic installations.

- AQ7282A: Ideal for networks less than 70 km.
- AQ7283A: Best for networks longer than 70 km with splitters.
- AQ7284A and AQ7285A: High dynamic range models for networks longer than 100 km.



Trace examples with pulse width of 1 μ s

AQ7283E, AQ7283F

These are maintenance models for live communication lines. They have a port for maintenance wavelengths of 1625 nm or 1650 nm, with a built-in cut filter to prevent interference with live communication traffic wavelengths.

- AQ7283E: Guarantees wavelength accuracy of 1625 nm \pm 10 nm for maintenance of 10GE-PON.
- AQ7283F: Guarantees a maximum output power of +15 dBm or less, allowing maintenance measurements on limited output power paths.

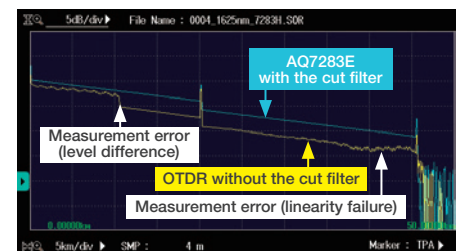

Trace examples of live communications lines

AQ7283H, AQ7284H, AQ7282G, AQ7283K

These models have three or four ports for different wavelengths. They measure at more than three wavelengths without switching optical connectors.

- AQ7283H and AQ7284H: Detect macro-bending useful for testing CWDM transmission paths.
- AQ7282G and AQ7283K: Suitable for installation checks of FTTH networks at 1490 nm.

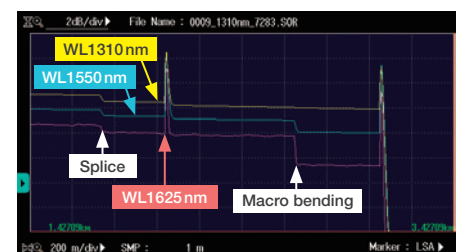

Trace examples with macro bending

AQ7286A, AQ7286H, AQ7286J

For optical fiber research and manufacturing

These models guarantee a center wavelength of \pm 15 nm at all wavelengths to meet the stringent light source performance requirements.

Optionally, a center wavelength of \pm 10 nm can be specified to meet the even more stringent standards compliant with IEC 60793-1-40.



Proven reliability

PON optimized

Quickly, easily, and correctly measure networks with large losses, such as Passive Optical Network (PON) systems. In PON mode, simply choose the configuration of the route to be measured on the screen, and the OTDR automatically determines the suitable measurement conditions to set the optimal values. Combined with the high SNR (HSN) mode, the AQ7280 OTDR series ensures high trace quality, even immediately after a large loss caused by an optical splitter.

Example of measuring PON with two splitters from the subscriber's house

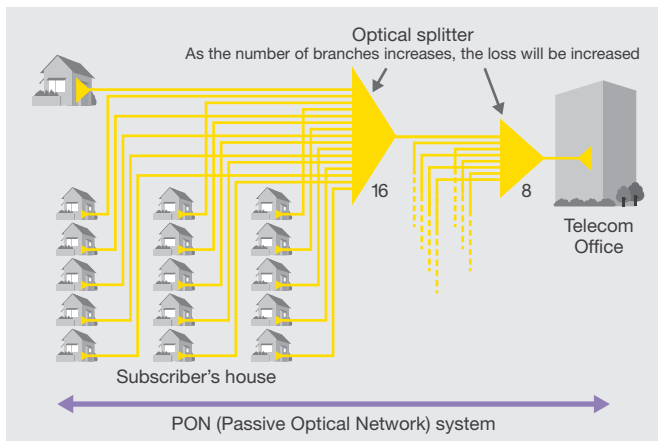

Set the route to be measured in PON mode



Measured in high SNR (HSN) mode



Example of measuring 128-port splitter with high SNR (HSN) mode

Hardware performance suitable for field use

Minimum sampling resolution
2 cm

Battery operating time
15 hours
compliant with Telcordia
GR-196-CORE Issue2 2010

Battery operating temperature range
-10 to 50°C

Advanced trace analysis

The OTDR main unit enables advanced analysis of measurement data

Type	Evaluation target
Multi-trace analysis	Multi-fiber cables
2-way trace analysis	Connection points with different loss values measured from both directions
Differential trace analysis	Aged deterioration of fibers
Section analysis	Total return loss of a certain section

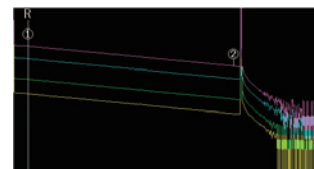

Multi-trace analysis

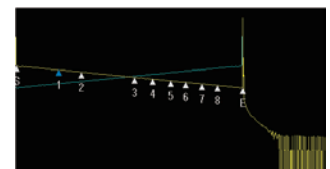

2-way trace analysis

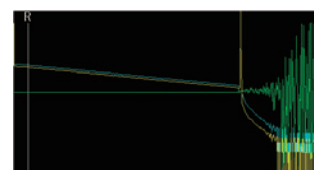

Differential trace analysis

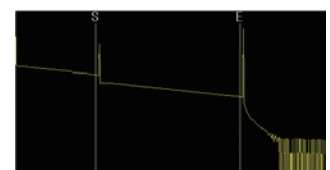

Section analysis

Quick and easy to use

8.4-inch high luminance color LCD

A large bright display shows trace details clearly even in outdoor sunlight. Engineers can easily check the screen when standing and the OTDR is on the floor for station measurement.



Trace display area expansion

The trace display area can be enlarged for viewing the trace in greater detail by sliding the on-screen menu or setting display. This feature makes the most of the 8.4-inch screen.

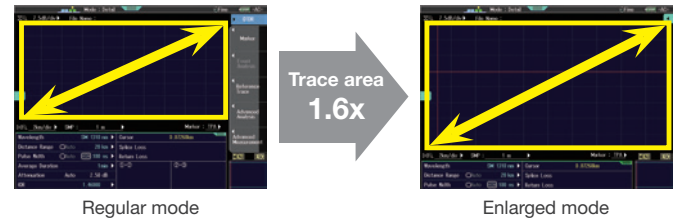

Multi-touch capacitive touchscreen

The intuitive multi-touch setup enables operations like pinch zooms and drag, similar to a smartphone or tablet.

*The touchscreen feature can be disabled for users who prefer the hardware key operations

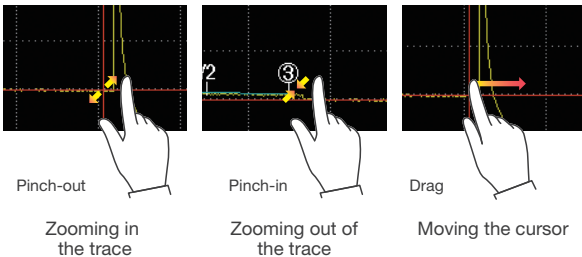

Handy window and shortcut icons

Switching to a different measurement condition while viewing the trace is available. Shortcut icons for popular functions like placement of markers and storage of data remain on the screen so that they can be executed directly without moving to a new menu.



Multi-language support

The AQ7280 OTDR series offers users multiple display languages including but not limited to: Chinese, Czech, Dutch, English, Finnish, French, German, Italian, Norwegian, Polish, Portuguese, Spanish, Swedish, and Turkish.



Shortcut icons (Initiation of measurement, file saving, etc.)

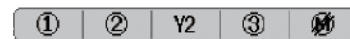

Icons for setting OTDR markers

Operability

Multi-fiber Measurement



A project file is created that defines the test conditions of each fiber, with the measured data managed in a fiber number table. From here, the fiber is selected to perform tests, and once these are completed, the fiber number color changes to help prevent omission and confusion.

Measuring each fiber of 180 optical fibers in an optical termination box

OTDR measurements, loss measurements and fiber surface inspection are repeated numerous times to test all the fibers.

OTDR measurement data per wavelength (SOR files)

Loss measurement data per wavelength (CSV file)

-3.87 dB

-2.41 dB

-2.63 dB

-2.63 dB

Fiber surface image (JPG/BMP file)

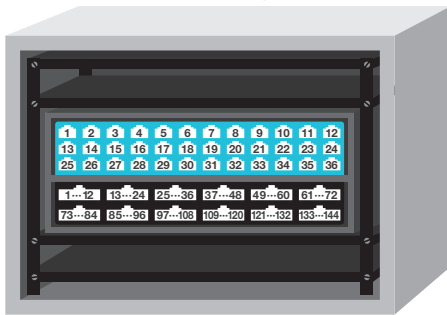

↓ Create a project file

File Name: 1550nm_0048_SOR | 2022/07/04 21:36

Wavelength 1: 1550nm

Distance Range: [] | Pulse Width: []

Pass: 40 | Fail: []

Create a table having the same configuration as an optical termination box (up to 2000 fibers)
Save the data with the same number as the fiber number

Smart Mapper

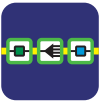

With Smart Mapper, users can press a single button and execute measurements, detect network events, and perform PASS/FAIL judgments. It includes a simple icon-based map view for easy interpretation of location and types of events, so even beginners can understand complex network configurations. PASS/FAIL judgments for each event are performed automatically based on thresholds specified in advance.

*SMP option of the OTDR main frame is required

Measuring a network from the station to antenna

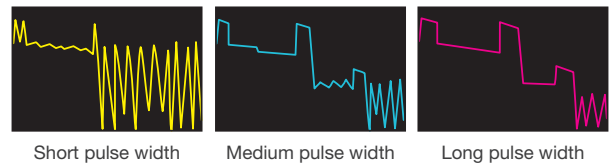
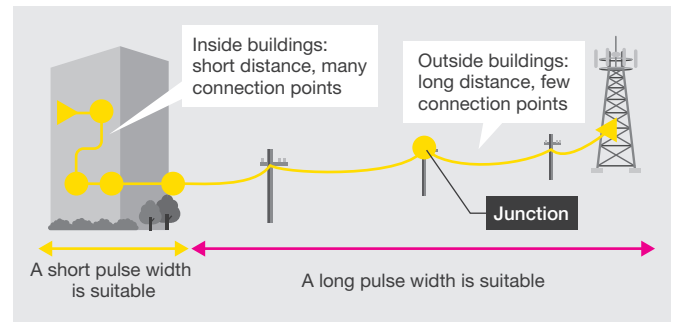

↓ Takes certain parts of the measured traces, links trace together

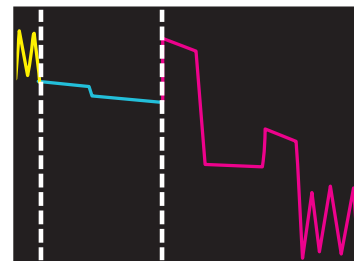

↓ Event analysis

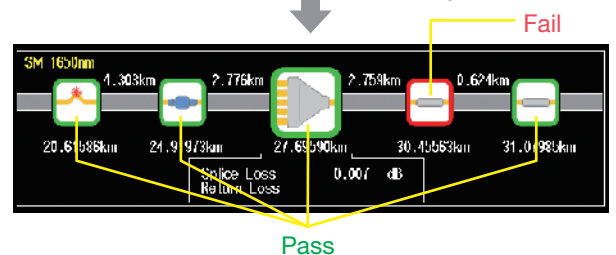

Schedule Measurement (Monitoring function)



OTDR measurements are automatically performed based on user-defined intervals to detect network connection interruptions caused by intermittent events. The dB value of a fixed point and the loss over a specific section are displayed in the logging view to check changes over time. Saved trace data and logging graph data can be analyzed later. *MNT option of the OTDR main frame is required

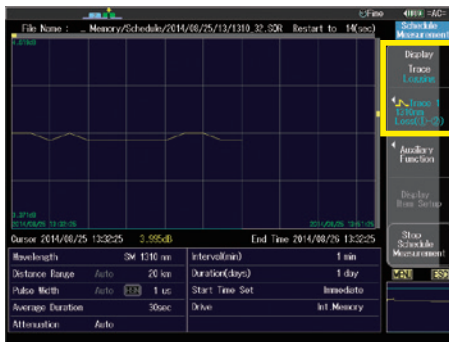

Example of logging the loss value between markers ① and ②

PDF Report



Built-in post-processing software generates OTDR reports in PDF format with flexible report template configurations. The report format is set and can be checked during layout preview and multiple reports can be created collectively.



Preview screen for creating report layout

Fault Locator

Easily and quickly identify fiber break locations with automatic break detection in optical fiber cables under test, based on selected network architectures, then display break distances. For additional analysis, switch to the OTDR mode with a single button press.

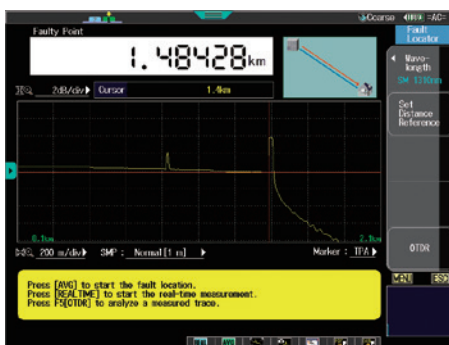

Example of detecting a breaking point 1.48 km away

File transfer and remote control

The AQ7280 OTDR series enables easy file transfer and remote control^{*1} via USB cable or wired LAN^{*2}. Engineers can add an OTDR to their company's local network and regularly check the status of an OTDR performing continuous measurement from a distance. If engineers are in an environment that allows external connection to the company's internal network, they can check the OTDR status regardless of their location.

*1 With a web browser, the AQ7933, or remote command.

*2 /LAN option of the OTDR main frame is required.

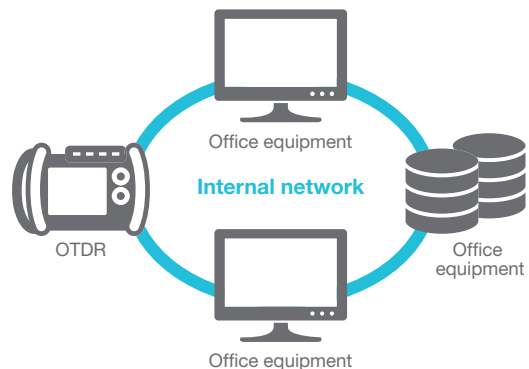

Much more than an OTDR

Available for both single tasks or multi-tasks, measurement functions that are required for optical fiber installation, replacement, and maintenance can be installed on the AQ7280 OTDR series of instruments, along with application software to support analysis.

Stabilized Light Source (OTDR unit option)



The light source feature via the OTDR port modulates and outputs light at OTDR wavelength and is used for measuring optical loss in combination with an OPM module or as a light source for optical fiber identification.

*/SLS option is required

Visible Light Source (VLS module)



Using a visible and continuous/modulated red light laser is an invaluable test option that checks the continuity of patch cords, launch fibers, and short fiber trunks. Breaks and bends in the fiber can easily be identified through visual inspection, as the visible light exits the fiber at the fault events. And since this feature uses a separate port from OTDR/OPM, another fiber is searchable while the OTDR/OPM is in use, which improves work efficiency. A flashing light emission is also available.

*Available on AQ4780, AQ2780V, or AQ2781V

Power Checker (OTDR unit option)



Power Checker is an optical power meter integrated via the OTDR port and is used to check optical power before making an OTDR measurement. As it uses the same port as the OTDR, there is no need to switch ports.

*/PC option is required

Only port 1 supports this feature, however AQ7286A, AQ7286H, and AQ7286J are not supported

Optical Power Meter (OPM module)



A modular optical power meter that attaches to the main frame, the OPM module supports a wide range of applications such as wavelength setting in 1 nm increments, modulation signal measurement, and multi-fiber measurement. It is usable with the stabilized light source (OTDR unit) for loss measurement and can also measure video services such as CATV and long distance transmission lines where an optical amplifier is used to boost the optical signal power.

*Available on AQ2780, AQ2781, AQ2780V, or AQ2781V

Fiber inspection probe



Fiber surface image display (standard feature)

Scratches and dirt on a fiber connector's surface can cause communication network failures, optical fiber deterioration, and can significantly affect OTDR measurement results. A video fiber inspection probe* enables visualization of a fiber connector's surface for inspection of defects.

For information of Verified Products, please visit:
<https://tmi.yokogawa.com/cp/0005/>



Fiber surface test function (option)

This feature automatically analyzes scratches and dirt on the fiber's surface and makes a PASS/FAIL judgment based on either IEC 61300-3-35-compatible criteria or other decision criteria dictated by the user. The surface image and judgment results are savable and available as PDF reports.

*/FST option and a recommended optical fiber inspection probe are required

*This feature is not available for multi-tasking

	Core	Cladding	Contact	Fiber Type	SM
Scratches	0	0	0	Standard	SPC
Defects	0	2	0		

Multi-tasking

Functions other than OTDR can be used at the same time by activating them from the OTDR measurement screen. This unique multi-tasking feature reduces measurement idle time during and revolutionizes the test process by enabling simultaneous parallel testing instead of serial testing. Stabilized light source, visible light source, power checker, optical power meter, fiber surface image display, and optical switch box are available for multi-tasking.

For example, you can ...

- Check one fiber while measuring another fiber with OTDR function
- Optical power meter → Optical power measurement
- Visible light source → Pair identification
- Optical fiber probe → Fiber surface inspection

*The OTDR, the stabilized light source and power checker functions cannot be used simultaneously. Fiber surface image display and optical switch box functions cannot be used simultaneously.



AQ7933 Emulation software

The AQ7933 emulation software displays and analyzes trace data measured on an OTDR and creates and outputs analysis reports via PC. Users can upload up to 1000 traces and the SOR software function sets events or markers on all loaded traces collectively.

*The AQ7933 can be downloaded from the YMI website. We offer a trial version of the software, in which all the functions are available for free for a trial period.

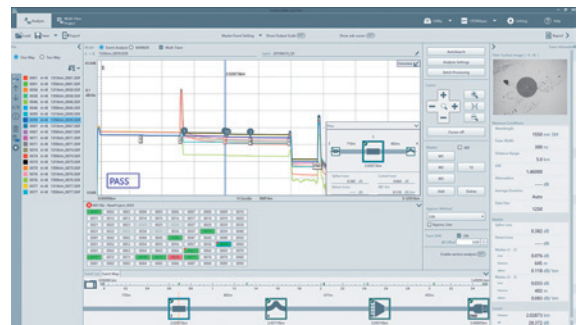

For information on products, please visit: https://tmi.yokogawa.com/p/p_aq7933/



AQ7940 Optical fiber monitoring software

The AQ7940 optical fiber monitoring software enables monitoring and detection of momentary interruptions on optical fiber networks. It detects interruptions of 200 ms or longer and automatically saves trace data before and after the detection. This PC application software allows users to search for the location of an interruption, something that previously was tedious and difficult to do.

*Use USB or Ethernet to connect a PC and the AQ7280. To use Ethernet, /LAN option of the OTDR main frame is required

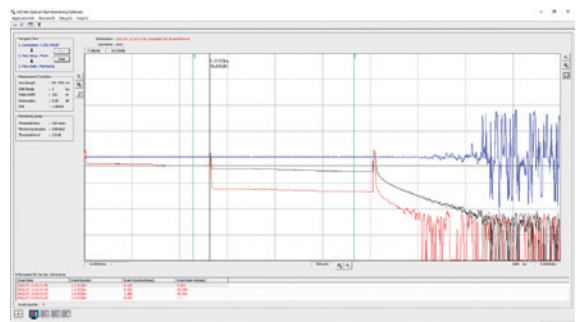

AQ3550 Optical Switch Box

The AQ3550 12-ch optical switch box for SMF works in conjunction with an OTDR. Control and power supply are performed from the OTDR main frame, while the optical switch box enables continuous measurement of all or a selection of the 12 channels. It is useful when measuring multiple fibers, such as optical fiber tape, under the same conditions.

Design

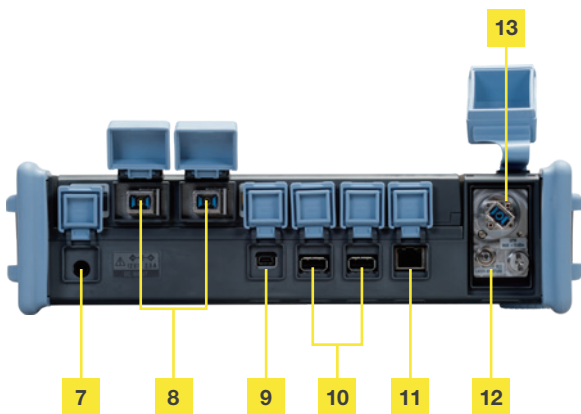
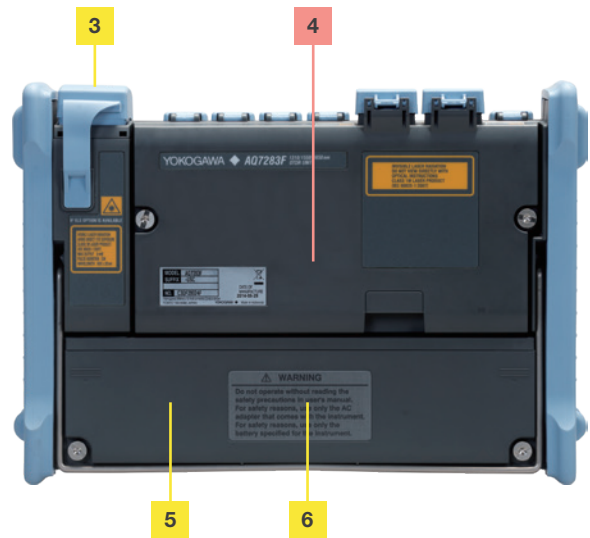
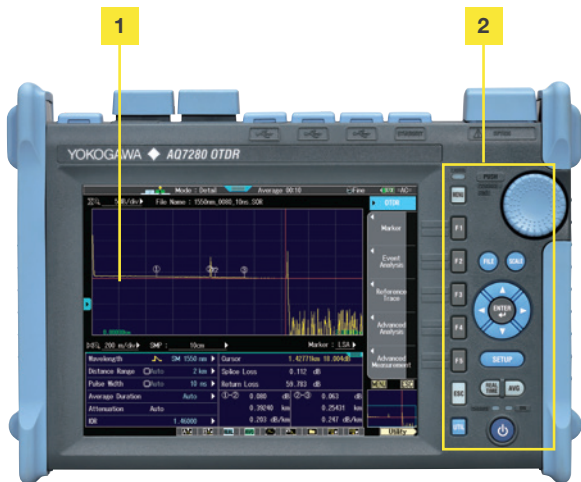

- 1** Multi-touch LCD touchscreen
- 2** Hard-key buttons
- 3** OPM/VLS module
- 5** Battery Pack (inside)
- 6** SD card slot (inside)
- 7** DC power input
- 8** OTDR/stabilized light source*/power checker* port
- 9** USB Type-B port (Mini-B)
- 10** USB Type-A ports

- 11** Ethernet port*
- 12** VLS port (VLS module)*
- 13** OPM port (OPM module)*
- 4** OTDR unit
(AQ7282A, AQ7283A, AQ7284A, AQ7285A, AQ7283E, AQ7283F, AQ7282G, AQ7283H, AQ7284H, AQ7283K)
- 14** OTDR unit with an air cooling fan
(AQ7286A, AQ7286H, AQ7286J)

*Option

Specifications

Note. All specifications are valid at 23°C±2°C, unless otherwise specified.

AQ7280 OTDR Mainframe

Items	Specifications
Display ¹	8.4-inch color TFT LCD (Resolution: 800 × 600, Multi-touch capacitive touchscreen)
Electrical interface	Unit interface × 1, Module interface × 1, USB 2.0 × 3 [Type-A × 2, Type-B (Mini-B) × 1] ² , Ethernet (10/100BASE-T, Option) × 1, SD card slot × 1
Remote control	USB Type-B (Mini-B), Ethernet (TCP/IP)
Data storage	Storage Internal storage: ≥1000 waveforms, External storage: USB memory, SD memory card
	File format Write: SOR, CSV, SET, BMP, JPG, CFG, PDF, SMP Read: SOR, SET, SMP
Dimensions	Approx. 287 mm (W) × 210 mm (H) × 80 mm (D) (excluding projections)
Weight	Approx. 2.2 kg (including internal battery and protectors, excluding OTDR unit and options)
OTDR functions	Minimum readout resolution Horizontal axis: 1 cm, Vertical axis: 0.001 dB
	Group refractive index 1.30000 to 1.79999 (in 0.00001 steps)
	Distance unit m, km, mile, kf
	Measurement Distance, Loss, Return loss, Section Return loss, dB/km
	Analysis Multi Trace Analysis, Two-Way Trace Analysis, Difference Trace Analysis, Section Analysis, Macro Bending Analysis
	Other functions Multi Fiber Project, Fault Locator, Work Completion Notice, File Report, Auto Event Search, Pass/Fail Judgment, Fiber Surface Test (Option), Schedule Measurement (Option), Smart Mapper (Option)

¹ The LCD may contain some pixels that are always ON or OFF (0.002% or fewer of all displayed pixels including RGB), but this is not indicative of a general malfunction.

² USB Type-A is for external memory, external printer, fiber inspection probe and optical switch box. USB Type-B (Mini-B) is for remote control and internal storage access with a PC.

General specifications

Items	Specifications
Environmental conditions	Operating temperature -10 to 50°C (0 to 40°C when AC adapter is being used. 0 to 35°C when the battery is being charged)
	Storage temperature -20 to 60°C
	Humidity 0 to 90% RH (20 to 90% with 739874 AC adapter, non-condensing)
	Altitude 4000 m
Power requirements	100 to 240 VAC, 50/60 Hz (AC adapter)
Battery	Type Lithium-ion
	Operating time ³ 15 hours (Telcordia GR-196-CORE Issue2 2010), 10 hours ⁴ (Continuous measurement)
	Recharge time ³ 6 hours
EMC ⁵	Emission EN 61326-1 Class A, EN 55011 Class A Group1
	Immunity EN 61326-1 Table2
Safety ⁶	EN 61010-1
	Laser EN 60825-1:2014+A11: 2021 Class 1 ⁸ IEC 60825-1:2007, GB 7247.1-2012 Class 1M ⁹ IEC 60825-1:2007, GB 7247.1-2012 Class 3R ^{6,10} EN 60825-1:2014+A11: 2021, IEC 60825-1:2007, GB 7247.1-2012 Class 3R ^{7,11} FDA 21CFR1040.10 ¹²

³ Typical ⁴ Power save mode, without an option module ⁵ AQ7280 OTDR mainframe together with an OTDR unit and an OPM/VLS module.

⁶ 1310 nm of AQ7284A, AQ7285A, AQ7284H, AQ7283K and AQ7286J OTDR units ⁷ The Visible Light Sources

⁸ Class 1

⁹ Class 1M

CLASS 1 LASER PRODUCT
(EN 60825-1:2014 + A11:2021)

INVISIBLE LASER RADIATION 不可见激光辐射
DO NOT VIEW DIRECTLY WITH 勿通过光学仪器直接观看光束
OPTICAL INSTRUMENTS 1M类激光产品
CLASS 1M LASER PRODUCT
(IEC 60825-1:2007, GB 7247.1-2012)

¹⁰ Class 3R

INVISIBLE LASER RADIATION 不可见激光辐射
AVOID DIRECT EYE EXPOSURE 避免眼睛受到直接照射
CLASS 3R LASER PRODUCT 3R类激光产品
(IEC 60825-1:2007, GB 7247.1-2012)
MAX OUTPUT 500mW WAVELENGTH 1310±25nm PULSE DURATION ≤20μs

¹¹ Class 3R

INVISIBLE LASER RADIATION 不可见激光辐射
AVOID DIRECT EYE EXPOSURE 避免眼睛受到直接照射
CLASS 3R LASER PRODUCT 3R类激光产品
(EN 60825-1:2014) (IEC 60825-1:2007, GB 7247.1-2012)
MAX OUTPUT 400mW WAVELENGTH 850±30nm PULSE DURATION ≤1μs

VISIBLE LASER RADIATION
AVOID DIRECT EYE EXPOSURE
CLASS 3R LASER PRODUCT
可见激光辐射
避免眼睛受到直接照射
3R类激光产品
(EN 60825-1:2014 + A11:2021)
(IEC 60825-1:2007, GB 7247.1-2012)
MAX OUTPUT 5mW
WAVELENGTH 650±20nm
PULSE DURATION CW

¹² 21CFR1040.10

Complies with 21 CFR 1040.10 and 1040.11 except for deviations pursuant to Laser Notice No.50, dated June 24, 2007
4-9-8 Myojin-cho, Hachioji-shi, Tokyo 192-8566, Japan

OTDR units

Note. All specifications are valid at 23°C±2°C, unless otherwise specified.

Items		Specifications									
Model		AQ7282A	AQ7283A	AQ7284A	AQ7285A	AQ7283E	AQ7283F	AQ7282G	AQ7283H	AQ7284H	
Wavelength (nm)		1310±25/1550±25				1310±25/ 1550±25, 1625±10	1310±25/ 1550±25, 1650±5 ^{*19} ±10 ^{*20}	1310±25/ 1490±15/ 1550±25	1310±25/1550±25/ 1625±25		
Optional wavelength (nm) (/10 N)		—	—	—	—	—	—	—	—	—	
Number of optical port		1				2 (Port 2: 1625 nm with filter)		2 (Port 2: 1650 nm with filter)		1	
Applicable fiber		SM (ITU-T G.652)									
Distance range (km)		0.2, 0.5, 1, 2, 5, 10, 20, 30, 50, 100, 200, 300, 400, 512									
Pulse width (ns)		3, 10, 20, 30, 50, 100, 200, 300, 500, 1000, 2000, 5000, 10000, 20000									
Event dead zone ^{*13} (m)		0.6			0.5	0.6					
Attenuation dead zone ^{*14} (m)		3.5/4				3.5/4, 4		3.5/4/4			
Dynamic range at 20 µs pulse width ^{*15} (dB)		38/36	42/40	46/45	50/50	42/40, 40		38/36/36	42/40/39	46/45/44	
Dynamic range at 1 µs pulse width ^{*16} (dB)		—									
Loss measurement accuracy (dB/dB) ^{*17}		±0.03									
Loss measurement repeatability (dB) ^{*18}		—	—	—	—	—	—	—	—	—	
Attenuation coefficient accuracy (dB/km) ^{*18}		—	—	—	—	—	—	—	—	—	
Attenuation coefficient repeatability (dB) ^{*18}		—	—	—	—	—	—	—	—	—	
Optical connector		Universal Adapter SC, FC, LC, and SC Angled-PC									
Laser class		1M ^{*27} or 1 ^{*28}		1M ^{*27} or 1 ^{*28} (1550 nm), 3R ^{*27} or 1 ^{*28} (1310 nm)		1M ^{*27} or 1 ^{*28}			1M ^{*27} or 1 ^{*28} (1550/1625 nm), 3R ^{*27} or 1 ^{*28} (1310 nm)		
Maximum optical pulse output power		—					≤+15 dBm (1650 nm)		—		
Power Checker (Integrated optical power meter) (PC)	Wavelength setting	1310/1490/1550/1625/1650 nm									
	Power range ^{*21}	-50 to -5 dBm									
	Measurement accuracy ^{*22}	±0.5 dB									
	Optical input port	OTDR port				OTDR port ^{*24}		OTDR port			
Stabilized Light Source (SLS)	Wavelength (nm)	1310±25/1550±25				1310±25/ 1550±25, 1625±10	1310±25/ 1550±25, 1650±5 ^{*25} ±10 ^{*26}	1310±25/ 1490±15/ 1550±25	1310±25/1550±25/ 1625±25		
	Optical output power	-3 dBm ±1 dB									
	Output power stability ^{*23} (dB)	±0.05/±0.05				±0.05/±0.05, ±0.15		±0.05/ ±0.15/ ±0.05		±0.05/±0.05/±0.15	
	Modulation mode	CW, 270 Hz, 1 kHz, 2 kHz									
	Optical output port	OTDR port									
	Laser class	1M ^{*27} or 1 ^{*28}									

*13 Pulse width: 3 ns, Return loss: ≥55 dB, Group refractive index: 1.5, at 1.5 dB below the unsaturated peak level, Typical

*14 Pulse width: 10 ns, Return loss: ≥55 dB, Group refractive index: 1.5, at a point where the backscatter level is within ±0.5 dB of the normal level, Typical

*15 Pulse width: 20000 ns, Measurement time: 3 minutes, SNR=1, Typical, Decrease by 0.5 dB with an angled-PC connector, Decrease by 0.5 dB with /SLS option for AQ7284A, AQ7285A and AQ7284H.

*16 Pulse width: 1000 ns, Measurement time: 1 minute, high SNR (HSN) mode, SNR=1, Typical, Decrease by 0.5 dB with an angled-PC connector

*17 For a loss 1 dB or less, the accuracy is ±0.05 dB

*18 Pulse width: 100 ns, Measurement time: 30 seconds, Distance range: 10 km, Sampling resolution: 1 m, Section distance: 3.2 km, 1 dB down from upper clip level, 13 dB up from SNR = 1, not applicable to 1383 nm, Stability: 2 sigma (repeatability only)

*19 At 20 dB below the spectral peak of pulsed optical output, at 23°C, after warm-up of 30 minutes

*20 At 60 dB below the spectral peak of pulsed optical output, at 23°C, after warm-up of 30 minutes

*21 CW, Safe maximum input power: 0 dBm (1 mW)

*22 CW, 1310 nm, -10 dBm, SM (ITU-T G.652)

*23 Constant temperature, 5 minutes after warm-up of 5 minutes

*24 Not applicable to port 2

*25 At 20 dB below the spectral peak of pulsed optical output, at 23°C, after warm-up of 30 minutes

*26 At 60 dB below the spectral peak of pulsed optical output, at 23°C, after warm-up of 30 minutes

*27 IEC 60825-1: 2007, GB 7247.1-2012

*28 EN 60825-1: 2014+A11: 2021

Items		Specifications			
Model		AQ7283K	AQ7286A	AQ7286H	AQ7286J
Wavelength (nm)		1310±25/1490±25/ 1550±25/1625±25	1310±15/ 1550±15	1310±15/ 1550±15/ 1625±15	1310±15/1383±2/ 1550±15/1625±15
Optional wavelength (nm) (/10 N)		—	1310±10/ 1550±10	1310±10/ 1550±10/ 1625±10	1310±10/1383±2/ 1550±10/1625±10
Number of optical port		1			
Applicable fiber		SM (ITU-T G.652)	SM (ITU-T G.652, ITU-T G.654, ITU-T G.657)		
Distance range (km)		0.2, 0.5, 1, 2, 5, 10, 20, 30, 50, 100, 200, 300, 400, 512			
Pulse width (ns)		3, 10, 20, 30, 50, 100, 200, 300, 500, 1000, 2000, 5000, 10000, 20000			
Event dead zone ^{*13} (m)		0.6			
Attenuation dead zone ^{*14} (m)		3.5/4/4/4	3.5/4	3.5/4/4	3.5/4/4/4
Dynamic range at 20 µs pulse width ^{*15} (dB)		42/38/40/40	42/40	42/40/39	42/39/40/39
Dynamic range at 1 µs pulse width ^{*16} (dB)		—	28/27	28/27/27	30/25/28/28
Loss measurement accuracy (dB/dB) ^{*17}		±0.03	±0.025 ^{*18}		
Loss measurement repeatability (dB) ^{*18}		—	±0.015		
Attenuation coefficient accuracy (dB/km) ^{*18}		—	±0.01		
Attenuation coefficient repeatability (dB) ^{*18}		—	±0.005		
Optical connector		Universal Adapter SC, FC, LC, and SC Angled-PC			
Laser class		1M ^{*27} or 1 ^{*28} (1490/1550/1625 nm), 3R ^{*27} or 1 ^{*28} (1310 nm)	1M ^{*27} or 1 ^{*28}		1M ^{*27} or 1 ^{*28} (1383/1550/1625 nm), 3R ^{*27} or 1 ^{*28} (1310 nm)
Maximum optical pulse output power		—			
Power Checker (Integrated optical power meter) (PC)	Wavelength setting	1310/1490/1550/1625/1650 nm	—	—	—
	Power range ^{*21}	−50 to −5 dBm	—	—	—
	Measurement accuracy ^{*22}	±0.5 dB	—	—	—
	Optical input port	OTDR port	—	—	—
Stabilized Light Source (SLS)	Wavelength (nm)	1310±25/1490±25/ 1550±25/1625±25	—	—	—
	Optical output power	−3 dBm ±1 dB	—	—	—
	Output power stability ^{*23} (dB)	±0.05/±0.15/±0.05/ ±0.15	—	—	—
	Modulation mode	CW, 270 Hz, 1 kHz, 2 kHz	—	—	—
	Optical output port	OTDR port	—	—	—
	Laser class	1M ^{*27} or 1 ^{*28}	—	—	—

Power Checker: Not applicable to AQ7286A, AQ7286H, AQ7286J and the port 2 of AQ7283E and AQ7283F Stabilized Light Source: Not applicable to AQ7286A, AQ7286H and AQ7286J

For all OTDR units

Items	Specifications
Sampling resolution	Min. 2 cm
Number of sampling points	Max. 256000
Distance measurement accuracy	±(0.75 m + measurement distance × 2 × 10 ^{−5} + sampling resolution)
Return loss measurement accuracy	±2 dB
Dimensions	Approx. 211 mm (W) × 110 mm (H) × 32 mm (D) (excluding projections)
Weight	Approx. 420 g (excluding AQ7286A, AQ7286H and AQ7286J), Approx. 460 g (AQ7286A, AQ7286H and AQ7286J)

OPM/VLS modules

Items		Specifications					
Model		AQ2780 OPM	AQ2781 High Power OPM	AQ2780V OPM & VLS	AQ2781V High Power OPM & VLS	AQ4780 VLS	
Optical Power Meter (OPM)	Wavelength setting	Simple mode: 850/1300/1310/1490/1550/1625/1650 nm, Detail mode: 800 to 1700 nm (1 nm steps), CWDM mode ^{*29} : 1270 to 1610 nm (20 nm steps)				—	
	Power range	CW	+10 to -70 dBm	+27 to -50 dBm ^{*30}	+10 to -70 dBm	+27 to -50 dBm ^{*30}	—
		CHOP	+7 to -70 dBm	+24 to -50 dBm ^{*30}	+7 to -70 dBm	+24 to -50 dBm ^{*30}	—
	Noise level ^{*31}	0.5 nW (-63 dBm)	50 nW (-43 dBm)	0.5 nW (-63 dBm)	50 nW (-43 dBm)	—	
	Applicable fiber	SM (ITU-T G.652), GI (50/125)				—	
	Uncertainty ^{*32}	±5%				—	
	Readout resolution	0.01 dB				—	
	Level unit	Absolute: dBm, mW, μW, nW, Relative: dB				—	
	Modulation mode	CW, 270 Hz, 1 kHz, 2 kHz				—	
	Averaging	1, 10, 50, 100 times				—	
	Data save	100 data per file (up to 1000 files)				—	
	Data logging	Logging intervals: 0.5, 1, 2, 5, 10 s., Number of data: 10 to 36000 data				—	
Optical connector	Universal Adapter: SC, FC, Ferrule Adapter: 1.25 dia, 2.5 dia.				—		
Visible Light Source (VLS)	Wavelength	—		650 ±20 nm		—	
	Optical output power	—		≥-3 dBm (Peak)		—	
	Modulation mode	—		CW, CHOP (Approx. 2 Hz)		—	
	Optical connector	—		2.5 mm ferrule type		—	
	Laser class	—		3R		—	
Dimensions	Approx. 47 mm (W) × 87 mm (H) × 29 mm (D) (excluding projections)					—	
Weight	Approx. 140 g					—	

*29 Not compatible with wavelength separation and simultaneous measurement

*30 1300 to 1600 nm

*31 1310 nm

*32 Input power: 100 μW (-10 dBm), CW, 1310 ±20 nm, Spectral width: ≤10 nm, SM (ITU-T G.652), FC/PC, Wavelength setting: Measured wavelength ±0.5 nm, excluding a secular change of equipment (add 1% one year after calibration)

Accessories for AQ7280 OTDR mainframe



Soft Carrying Case 739860



Battery Pack 739883



Shoulder Belt B8070CY



Optical Switch Box AQ3550

Accessories for OTDR units

Universal Adapter



SU2005A-SCC

SU2005A-FCC

SU2005A-LCC

Accessories for OPM modules

Universal Adapter



735480-SCC

735480-FCC

735481-LMC
(1.25 dia.)

735481-SFC
(2.5 dia.)

Dimensions

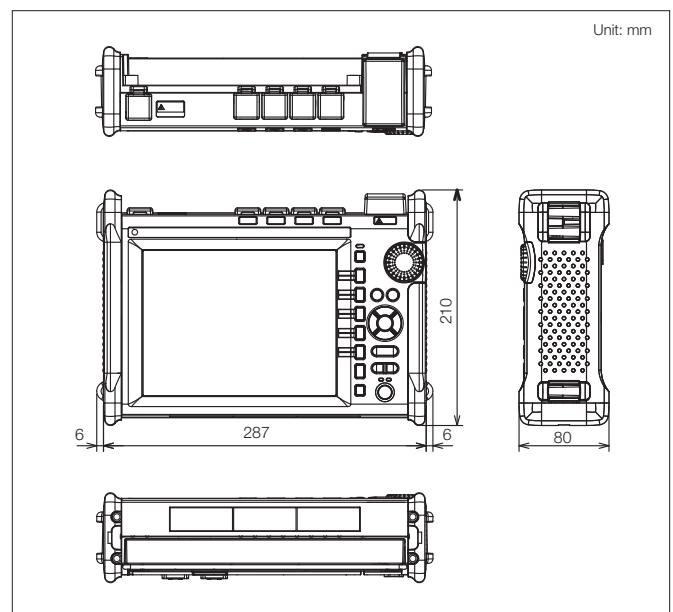

Ordering information

Minimum configuration

Sold separately

Not sold separately (Cannot be added after shipping)

AQ7280 series

Items	Models	Suffix codes	Descriptions	Selection types
OTDR Mainframe	AQ7280	-□□	OTDR Mainframe [Select one language: HJ, HE, HM, HC, HK, HR]	Required
		/LAN	Ethernet	Optional
		/MNT	Monitoring function	Optional
		/SMP	Smart Mapper function	
		/FST	Fiber Surface Test function	
		/SB	Shoulder Belt	
AC Adapter	739874	-□	AC Adapter [Select one power cord type]	Required
OTDR Unit	AQ728□□	—	OTDR Unit [Select one model]	Required
		-□□□	[Select one connector type: USC, UFC, ULC, ASC, NUA]	
		/PC	Power Checker (Integrated optical power meter)	Optional
		/SLS	Stabilized Light Source	Optional
		/10N	10 nm Wavelength Tolerance	Optional
OPM/VLS modules	AQ278□□	—	OPM (Optical Power Meter) [Select one model]	Optional
		-□□□	[Select one connector: SCC, FCC, LMC (1.25 mm dia.), SFC (2.5 mm dia.)] (Models with "V" include the VLS function.)	Optional
	AQ4780	—	VLS (Visible Light Source) (Fixed connector with 2.5 mm dia.)	Optional

Note. The OTDR mainframe, OTDR units, AC adapter, and OPM/VLS modules can be additionally purchased separately.

Accessories (Sold separately)

Items	Models	Suffix codes	Descriptions
Application software	AQ7933	-□□□	Emulation Software (Multi-language) [Select one medium: SP01 (download), SC01 (CD)]
	735071	-HE	AQ7940 Optical Fiber Monitoring Software (Language: English/Japanese)
Additional option license	735050	-□□□	Additional option license [Select one option code: MNT, SMP, FST]
Optical connector adapter (for OTDR)	SU2005A	-□□□	Universal Adapter [Select one connector type: SCC, FCC, LCC] (When OTDR connector is ASC, select SCC. The ASC is not compatible with FCC and LCC.)
Optical connector adapter (for OPM)	735480	-□□□	Universal Adapter [Select one connector type: SCC, FCC]
	735481	-□□□	Universal Adapter [Select one connector type: LMC (1.25 mm dia.), SFC (2.5 mm dia.)]
Carrying case	739860	—	Soft Carrying Case
Battery	739883	—	Battery pack (spare)
Belt	B8070CY	—	Shoulder Belt
Optical switch	AQ3550	-112-SA-SCC	AQ3550 Optical Switch Box

AQ7280 order example

1) Requested items

Purpose	Installation work of a long-distance network
Required wavelength	1310 nm, 1550 nm
Required connector	FC
Required functions	Stabilized Light Source, Power Checker, LAN, Monitoring function

↓ The three items order is required

OTDR mainframe	AQ7280-□□/MNT/LAN
AC adapter	739874-□
OTDR unit	AQ7285A-UFC/PC/SLS

2) Requested items

Purpose	Installation and maintenance swork of a middle-distance
Required wavelength	1310 nm, 1550 nm, 1650 nm
Required connector	SC, FC
Required functions	Stabilized Light Source, LAN, Optical Power Meter, Visible Light Source, Shoulder Belt

↓ The six items seven pieces order is required

OTDR mainframe	AQ7280-□□/LAN/SB	
AC adapter	739874-□	
OTDR unit	AQ7283F-USC/SLS	
OPM/VLS module	AQ2780V-SCC	
Additional connector	For OTDR unit	SU2005A-FCC (2 pieces required)
	For OPM module	735480-FCC

3) Requested items

Purpose	Installation work of CWDM network with multiple fibers
Required wavelength	1310 nm, 1550 nm, 1625 nm
Required connector	SC Angled-PC
Required functions	Stabilized Light Source, Optical Power Meter, Fiber Surface Test function, Smart Mapper, Optical Switch Box

↓ The five items order is required

OTDR mainframe	AQ7280-□□/FST/SMP
AC adapter	739874-□
OTDR unit	AQ7283H-ASC/SLS
OPM module	AQ2780-SCC
Optical switch box	AQ3550-112-SA-SCC

* Please prepare the recommended optical fiber inspection probe.

Models and suffix codes

OTDR Mainframe

Models	Suffix codes	Descriptions
AQ7280		AQ7280 OTDR Mainframe
Language	-HJ	Japanese/English
	-HE	English (Multi-language)
	-HM	Chinese
	-HC	Chinese/English
	-HK	Korean/English
	-HR	Russian/English
Options	/MNT	Monitoring function
	/SMP	Smart Mapper function
	/FST	Fiber Surface Test function
	/LAN	Ethernet
	/SB	Shoulder Belt

Standard accessories: Battery pack, hand belt, user's manual (CD-ROM), operation guide

AC adapter (Not included in AQ7280. Please order separately.)

Models	Suffix codes	Descriptions
739874		AC Adapter ^{*1}
Power cord	-D	UL/CSA standard, 125 V
	-F	VDE standard, 250 V
	-H	Chinese standard, 250 V
	-N	Brazilian standard, 250 V
	-P	Korean standard, 250 V
	-Q	BS/Singaporean standard, 250 V
	-R	Australian standard, 250 V
	-T	Taiwanese standard, 125 V
	-A	Argentine standard, 250 V

*1 For outside the countries that require CE marking.

OTDR units

Models	Suffix codes	Descriptions
AQ7282A		2WL 1310/1550 nm 38/36 dB
AQ7283A		2WL 1310/1550 nm 42/40 dB
AQ7284A		2WL 1310/1550 nm 46/45 dB
AQ7285A		2WL 1310/1550 nm 50/50 dB
AQ7283E		3WL 1310/1550,1625 nm with filter 42/40, 40 dB
AQ7283F		3WL 1310/1550,1650 nm with filter 42/40, 40 dB
AQ7282G		3WL 1310/1490/1550 nm 38/36/36 dB
AQ7283H		3WL 1310/1550/1625 nm 42/40/39 dB
AQ7284H		3WL 1310/1550/1625 nm 46/45/44 dB
AQ7283K		4WL 1310/1490/1550/1625 nm 42/38/40/40 dB
AQ7286A		2WL 1310/1550 nm 42/40 dB
AQ7286H		3WL 1310/1550/1625 nm 42/40/39 dB
AQ7286J		4WL 1310/1383/1550/1625 nm 42/39/40/39 dB
Optical connector	-USC	Universal Adapter (SC)
	-UFC	Universal Adapter (FC)
	-ULC	Universal Adapter (LC)
	-ASC	Universal Adapter (SC Angled-PC)
	-NUA	No universal adapter
Options	/PC	Power Checker ^{*2}
	/SLS	Stabilized Light Source ^{*2}
	/10N	10 nm Wavelength Tolerance ^{*3}

*1 Not applicable to the port 2 of AQ7283E and AQ7283F

*2 Not applicable to AQ7286A, AQ7286H and AQ7286J

*3 Applicable to AQ7286A, AQ7286H and AQ7286J only



Minimum configuration: The OTDR mainframe + OTDR units + AC adapter + OPM/VLS modules (option)
 This is a Class A instrument based on Emission standards EN61326-1 and EN55011, and is designed for an industrial environment.
 Operation of this equipment in a residential area may cause radio interference, in which case users will be responsible for any interference which they cause.



YOKOGAWA TEST & MEASUREMENT CORPORATION

Global Sales Dept. /E-mail: tm@cs.jp.yokogawa.com

YOKOGAWA CORPORATION OF AMERICA
 YOKOGAWA EUROPE B.V.
 YOKOGAWA TEST & MEASUREMENT (SHANGHAI) CO., LTD.
 YOKOGAWA ELECTRIC KOREA CO., LTD.
 YOKOGAWA ENGINEERING ASIA PTE. LTD.
 YOKOGAWA INDIA LTD.
 YOKOGAWA ELECTRIC CIS LTD.
 YOKOGAWA AMERICA DO SUL LTDA.
 YOKOGAWA MIDDLE EAST & AFRICA B.S.C(c)

<https://tmi.yokogawa.com/us/>
<https://tmi.yokogawa.com/eu/>
<https://tmi.yokogawa.com/cn/>
<https://tmi.yokogawa.com/kr/>
<https://tmi.yokogawa.com/sg/>
<https://tmi.yokogawa.com/in/>
<https://tmi.yokogawa.com/ru/>
<https://tmi.yokogawa.com/br/>
<https://tmi.yokogawa.com/bh/>

OPM/VLS modules

Models	Suffix codes	Descriptions
AQ2780		OPM Module
AQ2781		High Power OPM Module
AQ2780V		OPM & VLS Module
AQ2781V		High Power OPM & VLS Module
Optical connector	-SCC	Universal Adapter (SC)
	-FCC	Universal Adapter (FC)
	-LMC	Ferrule Adapter (1.25 dia.)

Models	Suffix codes	Descriptions
AQ4780		VLS Module

Accessories (Sold separately)

Models	Names	Descriptions
SU2005A-SCC	Universal Adapter (SC)	for OTDR unit (Shared by -USC & -ASC)
SU2005A-FCC	Universal Adapter (FC)	for OTDR unit
SU2005A-LCC	Universal Adapter (LC)	for OTDR unit
735480-SCC	Universal Adapter (SC)	for OPM module
735480-FCC	Universal Adapter (FC)	for OPM module
735481-LMC	Ferrule Adapter (1.25 dia.)	for OPM module
735481-SFC	Ferrule Adapter (2.5 dia.)	for OPM module
739860	Soft Carrying Case	
739883	Battery Pack	
B8070CY	Shoulder Belt	
AQ3550-112-SA-SCC	AQ3550 Optical Switch Box (SC)	for SM

*All universal adapters of OPM module are Angled-PC compatible.

Additional option license

Models	Suffix codes	Descriptions
735050		Additional option license for AQ7280
	-MNT	Monitoring function
	-SMP	Smart Mapper function
	-FST	Fiber Surface Test function

Application software

Models	Suffix codes	Descriptions
AQ7933		AQ7933 Emulation Software
	-SP01	Download version (1-license)
	-SC01	Package version (1-license with CD)
735071		AQ7940 Optical Fiber Monitoring Software
	-HE	English/Japanese

Notice

- Before operating the product, read the user's manual thoroughly for proper and safe operation.
- Any company names and product names mentioned in this document are trade names, trademarks or registered trademarks of their respective companies.
- "Typical" or "Typ." in this document means "Typical value", which is for reference, not guaranteed specification.
- Three-year warranty is for the OTDR mainframe, OTDR units, and OPM/VLS modules.

■ Microsoft, MS, and Windows are registered trademarks or trademarks of Microsoft Corporation in the US and other countries.
 Other company names and product names appearing in this document are the registered trademarks of their respective companies.

Yokogawa's Approach to Preserving the Global Environment

- Yokogawa's electrical products are developed and produced in facilities that have received ISO14001 approval.
- In order to protect the global environment, Yokogawa's electrical products are designed in accordance with Yokogawa's Environmentally Friendly Product Design Guidelines and Product Design Assessment Criteria.

NOTICE

- Before operating the product, read the user's manual thoroughly for proper and safe operation.

<https://tmi.yokogawa.com/>

YMI-N-MI-M-E03

The contents are as of May 2024. Subject to change without notice.
 Copyright © 2014, Yokogawa Test & Measurement Corporation
 [Ed: 10/b] Printed in Japan, 405(KP)